

LITTLE WONDER[®]

OPTIMAX

Maximum Output Blower

MODELS: 9390-06-01
CH440 KOHLER

9270-02-01
GX270 HONDA

9270-03-01
EX270 SUBARU

9270-06-01
CH395 KOHLER

9390-02-01
GX390 HONDA

9570-04-01
570 VANGUARD



MAN 4166749

Rev. E 5-26-2022

Original Language Instructions

**Owners Manual and Safety Instructions for
OPTIMAX BLOWER**

OPERATORS / PARTS MANUAL

CALIFORNIA PROPOSITION 65



WARNING: Cancer and Reproductive Harm - www.P65Warnings.ca.gov.



ADVERTENCIA: Cáncer y Daño Reproductivo - www.65Warnings.ca.gov.

WARNING

The engine exhaust from this product contains chemicals known to the State of California to cause cancer, birth defects or other reproductive harm.

ADVERTENCIA

El estado de California hace saber que los gases de escape de este producto contienen productos químicos que producen cáncer, defectos de nacimiento y otros daños en el proceso de reproducción humana.

LITTLE WONDER BLOWER

IMPORTANT MESSAGE

This Operation / Part Manual provides the information necessary for safe and efficient operation and service. For your safety, it is important that you read and understand this entire manual before operating your equipment. This Operator's Manual is part of the machine. Suppliers of both new and second-hand machines must make sure that this manual is provided with the machine. Learn the proper operation of all controls. Observe all safety precautions. Follow all instructions and warnings completely. Do not remove or defeat any safety features.

Schiller Grounds Care, Inc.
1028 Street Road Southampton, PA 18966
PHONE 877-596-6337 • FAX 215-357-8045

TABLE OF CONTENTS	PAGE
SAFETY.....	4
SET UP INSTRUCTIONS.....	9
CONTROLS.....	11
OPERATION/MAINTENANCE/STORAGE.....	12
ADJUSTMENTS.....	13
FAN REMOVAL AND INSTALLATION.....	14
ENGINE ASSEMBLY.....	16
HOUSING ASSEMBLY.....	17
WARRANTY.....	18



This Operator's Manual is part of the machine. Suppliers of both new and second-hand machines must make sure that this manual is provided with the machine.

DETAILS

MEASUREMENTS

U.S. Units of measure are used in this manual.

SERIAL NUMBERS

Write frame and engine serial numbers, plus model numbers in "Owner's Record" section below. You may need these numbers when you order parts.

ORDERING PARTS

When ordering parts, always give serial number and model of your machine as well as the quantity, part number and description of the part needed.

DIRECTIONS

"Right Hand" and "Left Hand" sides of the machine are determined by facing the "back" of the machine as you would operate the machine.

OWNER'S RECORD

DATE PURCHASED _____
 MODEL NUMBER _____
 SERIAL NUMBER _____
 ENGINE MODEL NUMBER _____
 ENGINE SERIAL NUMBER _____

NOTICE !!!

Unauthorized modifications may present **extreme** safety hazards to operators and bystanders and could also result in product damage.

Schiller Grounds Care, Inc. strongly warns against, rejects and disclaims any modifications, add-on accessories or product alterations that are not designed, developed, tested and approved by Schiller Grounds Care, Inc. Engineering Department. Any Schiller Grounds Care, Inc. product that is altered, modified or changed in any manner not specifically authorized after original manufacture-including the addition of "after-market" accessories or component parts not specifically approved by Schiller Grounds Care, Inc.-will result in the Schiller Grounds Care, Inc. Warranty being voided.

Any and all liability for personal injury and/or property damage caused by any unauthorized modifications, add-on accessories or products not approved by Schiller Grounds Care, Inc. will be considered the responsibility of the individual(s) or company designing and/or making such changes. Schiller Grounds Care, Inc. will vigorously pursue full indemnification and costs from any party responsible for such unauthorized post-manufacture modifications and/or accessories should personal injury and/or property damage result.

- **DO NOT** change engine governor settings or overspeed the engine.
- **Operating the engine at excessive speed can cause damage to the unit that is not covered under the warranty.**



This symbol means:
ATTENTION!
BECOME ALERT!

Your safety and the safety of others is involved.

Signal word definitions:

The signal words below are used to identify levels of hazard seriousness. These words appear in this manual and on the safety labels attached to Schiller Grounds Care, Inc. machines. For your safety and the safety of others, read and follow the information given with these signal words and/or the symbol shown above.

DANGER

DANGER indicates an imminently hazardous situation which, if not avoided, **WILL** result in death or serious injury.

WARNING

WARNING indicates a potentially hazardous situation which, if not avoided, **COULD** result in death or serious injury.

CAUTION

CAUTION indicates a potentially hazardous situation which, if not avoided, **MAY** result in minor or moderate injury. It may also be used to alert against unsafe practices or property damage.

CAUTION

CAUTION used without the safety alert symbol indicates a potentially hazardous situation which, if not avoided, **MAY** result in property damage.

SCHILLER GROUNDS CARE, INC.
1028 Street Rd.
Southampton, PA 18966
MODEL NUMBER

SERIAL NUMBER
MFG. DATE:

MODEL NUMBER: This number appears on sales literature, technical manuals and price lists.

SERIAL NUMBER: This number appears only on your unit. It contains the model number followed consecutively by the serial number. Use this number when ordering parts or seeking warranty information.

OPERATOR PREPARATION AND TRAINING

- Read the operation manual.
- Read the engine manufacturer's owner manual.
- Explain this material to any operator or mechanic who cannot read English.
- Contact your factory representative for clarification if any portion of this material is unclear.
- Adhere to the warnings and instructions depicted in the safety decals on the machines.
- Replace any missing or damaged labels.
- Keep warning labels and this operator's manual legible and intact.
- Become familiar with the safe operation of the equipment, operator controls and safety signs.
- Know how to stop the engine and attachments quickly in an emergency.
- Do not operate or allow another person to operate this machine if there are any questions about safety.
- Train all operators and mechanics; the owner is responsible for training the users and for accidents or injuries occurring to themselves, other people or property.
- Never attempt to use a machine that is damaged or has unauthorized modifications.
- Wear appropriate clothing, including long trousers and gloves.
- Do not operate barefoot or wearing open sandals.
- Do not operate with loose clothing, long hair or jewelry which may get tangled in moving parts.
- Wear hearing protection.
- Wear safety glasses with side shields.
- Wear a dust mask to avoid breathing dust.
- Never allow underage children (as defined by local regulations), unskilled or improperly trained people to operate this equipment.
- Do not operate machine while under the influence of drugs, alcohol, or any other condition of impairment.
- The owner/user can prevent and is responsible for accidents or injuries occurring to themselves, other people or property.

SITE PREPARATION AND CIRCUMSTANCES

- Evaluate the terrain to determine what accessories and attachments are needed to properly and safely perform the job.
- Only use accessories and attachments approved by the manufacturer.
- Remove all objects or debris from the area that may be picked up or thrown by the machine.
- Keep pets and people, especially young children, away from the area and immediately cease operation of the equipment if any enter the area.
- Operate only in daylight or in good artificial light.
- Evaluate the terrain to determine how to safely perform the job.

MACHINE PREPARATION

- Do not tamper with or defeat safety devices; they exist for your protection.
- Keep guards, shields and interlocked safety devices in place and in proper working condition.
- Keep all fasteners—nuts, bolts and pins—secured.
- Visually inspect tines for wear or damage and replace worn or damaged parts.
- Verify that machine and attachments, if any, are in good operating condition.

OPERATION SAFETY

GENERAL

- Use extra care when loading or unloading the machine into a trailer or truck.
- Do not run the engine in an enclosed area where dangerous carbon monoxide fumes can collect.
- Never leave a running machine unattended. Always stop engine when leaving the operator position.
- Do not blow towards people, cars, windows, or other items which could be injured or damaged by the blown debris.
- Keep hands away from the blower air intake and outlet.

STARTING

- Start according to instructions in this manual or on the machine.
- Do not change engine governor settings or overspeed the engine. Operating the engine at excessive speed can increase the hazard of personal injury.

OPERATING ON SLOPES

 **WARNING**

USE EXTRA CARE WHEN OPERATING ON SLOPES. EVALUATE THE RISKS INVOLVED BEFORE OPERATING ON A SLOPE

- Slopes are a major factor related to slip and fall accidents that sometimes lead to severe injury or death. All slopes require extra caution.
- Be sure of your footing on slopes
- Do not operate on slopes if uneasy or uncertain. Ultimate responsibility for safe operation on slopes rests with the operator.
- Do not operate on steep slopes.
- Keep all movement on slopes slow and gradual.
- Do not operate near drop-offs, ditches or embankments.
- Do not turn on slopes unless necessary. Turn slowly and downhill when possible.
- Watch for holes, ruts, bumps, rocks and other hidden objects. Uneven terrain could cause a slip and fall accident. Tall grass can hide objects.

INTERRUPTING OPERATION

- Before leaving the operator's position:
 - Park on level ground.
 - Reduce the throttle setting.
 - Shut off the engine.
 - Turn off the fuel if the machine is equipped with a shut-off valve.
- Before refueling:
 - Park on level ground.
 - Reduce the throttle setting.
 - Shut off the engine.
 - Turn off the fuel if the machine is equipped with a shut-off valve.
 - Wait for the fan to stop.
- Before checking, cleaning, clearing blockages or working on the machine:
 - Park on level ground.
 - Reduce the throttle setting.
 - Shut off the engine.
 - Turn off the fuel if the machine is equipped with a shut-off valve.
 - Wait for the fan to stop.
 - Disconnect the spark plug wire.
- Immediately shut off the machine if it begins to vibrate abnormally. Do not restart until inspection and repairs have been made.
- For repairs or adjustments where the engine must be running, such as for carburetor adjustments, keep hands and feet clear of moving parts.

MAINTENANCE SAFETY

GENERAL

- Maintain machine according to manufacturer's schedule and instructions for maximum safety and best results.
- Park machine on level ground.
- Never allow untrained personnel to service machine.
- Guards should only be removed by a qualified technician for maintenance or service.
- Adjust or repair only after the engine has been stopped and the fan has stopped moving.
- Disconnect spark plug wire(s) before doing any maintenance.
- Replace parts if worn, damaged or faulty. For best results, always replace with parts recommended by the manufacturer.
- Do not dismantle the machine without releasing or restraining forces which may cause parts to move suddenly.
- Provide adequate support, e.g. jack stands for lifted machine or parts if working beneath.
- Do not put hands or feet near or under rotating parts.
- Clean up spilled oil or fuel thoroughly.
- Replace faulty mufflers.
- To reduce fire hazards, keep the engine, muffler, and fuel storage area free of grass, leaves, debris buildup or grease.

FANS

Do not straighten or weld fans. Replace damaged or failed fans..

FUEL



FLAMMABLE! USE EXTRA CARE WHEN HANDLING ALL FUELS.





- Gasoline (petrol) and diesel fuels are flammable; gasoline (petrol) vapors are explosive. Use extra care when handling.
- Store only in containers specifically designed for fuel.
- When refueling or checking fuel level:
 - Stop the engine and allow to cool
 - Do not smoke
 - Refuel outdoors only
 - Use a funnel
 - Do not overfill
 - If fuel is spilled, do not attempt to start the engine until the spill is cleaned up and vapors have cleared.
 - Securely replace caps on fuel containers and tanks.
- To prevent static electricity sparks:
 - Keep containers electrically grounded. Do not fill containers in a vehicle or on a truck or trailer bed with a plastic liner. Fill containers on the ground away from the vehicle.
 - When practical, remove gasoline (petrol) powered equipment from the truck or trailer and refuel it on the ground. If equipment must be refueled on the truck or trailer, refuel from a portable container rather than a dispenser nozzle.
 - Keep the dispenser nozzle in contact with the rim of the fuel tank or container opening until fueling is complete. Do not use a nozzle lock-open device.
- If fuel is spilled on clothing, change it immediately.

STORAGE SAFETY

- Stop the engine and allow to cool before storing.
- Drain the fuel tank outdoors only.
- Store fuel in an approved container in a cool, dry place.
- Keep the machine and fuel containers in a locked storage place to prevent tampering and to keep children from playing with them.
- Do not store the machine or fuel container near an open flame, spark, or appliance, such as a water heater, or a pilot light.
- Keep gasoline (petrol) storage area free of grass, leaves and excessive grease to reduce fire hazard.
- Clean grass and debris from cutting units, drives, mufflers and engine to help prevent fires.

SAFETY DECALS

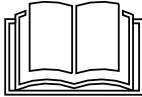

An important part of the safety system incorporated in this blower are the warning labels found on the blower. Replace labels if damaged or illegible.

 WARNING	 ADVERTENCIA
 	<p>Antes de comenzar:</p> <ul style="list-style-type: none"> -Lea y entienda el manual del operador y las etiquetas. -Pide que alguien lea y explique el manual y las etiquetas a usted si usted no lee Inglés. -Use protección ocular y auditiva. -No haga funcionar sin los protectores en su lugar. -Pare el motor antes de dar servicio -La gente a más durante la operación.
<p>BEFORE STARTING:</p> <ul style="list-style-type: none"> -Read and understand Operator manual and labels. -Wear hearing and eye protection. -Replace labels and Operator manual if lost or damaged. 	<small>4165977</small>

 DANGER

<p>Fan blades can cut/crush.</p> <ul style="list-style-type: none"> -Keep hands and feet away. -Stop engine and remove spark plug wire before servicing. -Do not operate without guards in place.
 WARNING

<p>Thrown objects</p> <ul style="list-style-type: none"> -Keep bystanders away. -Do not blow toward people or pets. -Do not blow toward items that may be damaged by flying debris.
<small>4165975</small>



D E F L E C T O R

<small>4165913</small>

4165913 USED ON REMOTE
HORIZONTAL DEFLECTOR MODELS
ONLY

LITTLE WONDER BLOWER

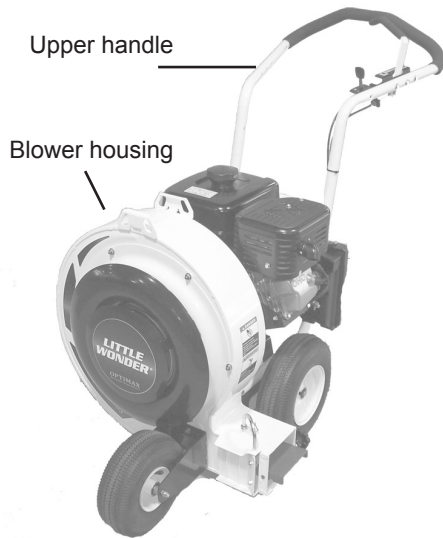
SET-UP INSTRUCTIONS

SET-UP INSTRUCTIONS



1. Open box. Remove upper handle and cardboard insert.
2. Lay box down with blower housing up. Use lower handle to roll unit out of the box.
3. Locate hardware package.
4. Install upper handle to lower handle with (4) 3/8-16 x 1-34 carriage bolts and (4) 3/8-16 flanged nylon insert nuts from the hardware package. Tighten the nuts securely but not so much as to crush the tube. (Figure 1)
5. Route the throttle cable in front of lower handle crossbar. Install to the left side of the upper handle with (2) 10-32 x 1/2 thread forming screws from the hardware package. (Figure 2)
6. Ensure the center link of the chain is on the center tooth of the deflector sprocket before connecting the deflector cable. (Figure 3)



FIGURE 1

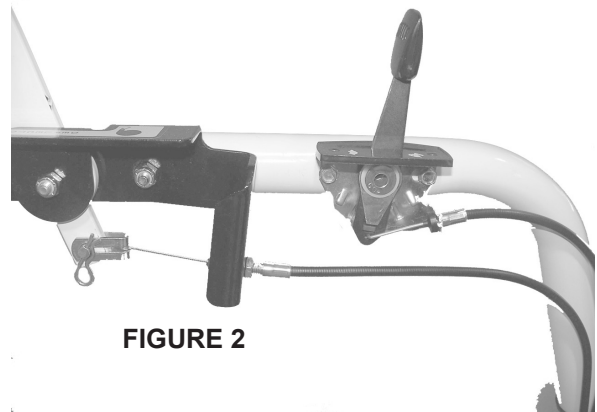

FIGURE 2

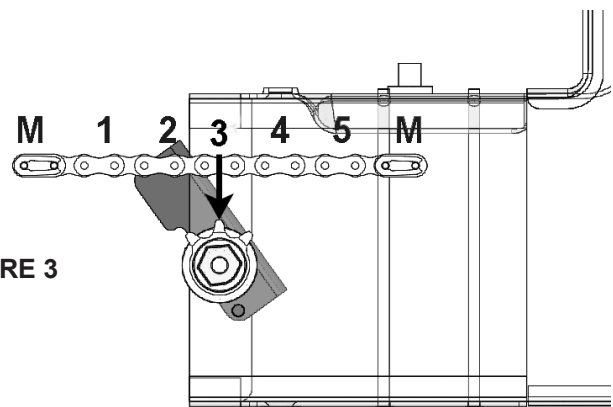

FIGURE 3

SET-UP INSTRUCTIONS (continued)

7. Route the deflector cable above the axle and in front of the lower handle cross bar. Remove one of the nuts and the boot from the end of the deflector cable and install the cable through the key slot into the bracket on the upper handle. Reconnect the clevis from the control lever and install over the end of the cable. Reconnect the clevis to the control lever with a $\frac{1}{4}$ x $\frac{5}{8}$ clevis pin and hairpin cotter. (Note: The deflector can be moved and held in place with the locking knob to help connect the clevis fitting to the control lever. Move the control lever to the rear to more easily connect the cable. Loosen the knob so the deflector moves freely after the clevis is connected. (Figure 4)
8. Move the deflector control lever to the rear of the slot. Adjust the jam nuts on the cable fitting so the deflector is completely closed. Lock the nuts against the bracket when the adjustment is correct.
9. Secure the throttle and deflector cables to the handle tubes with cable ties from the hardware package. Trim off excess. (Figure 5)
10. Fill the engine with oil and fuel as instructed in the Engine Manual.

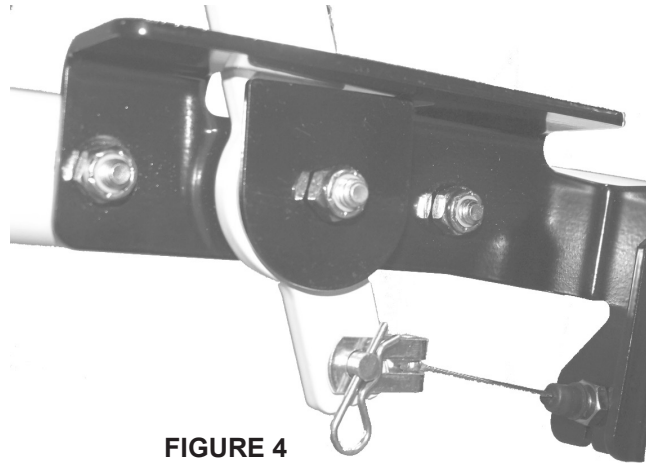

FIGURE 4



FIGURE 5

LITTLE WONDER BLOWER

CONTROLS

(BLOWER SHOWN WITH SUBARU EX40 ENGINE.
OTHER ENGINES ARE SIMILAR.)

SWITCH (A)

Move to the "OFF" position to stop the engine.
Move to the "ON" position before starting engine.
Note: On Kohler engines, this SWITCH is
incorporated in the FUEL SHUT-OFF (D)

THROTTLE (B)

Controls engine speed and the amount of air
being blown.



CHOKE (C)

Move to the "CHOKE" position to apply the
choke. Move to the "RUN" position to remove
the choke.

FUEL SHUT OFF (D)

Move to the "OFF" position to shut off the fuel
whenever transporting the machine by trailer
or truck or during storage. Move to the "ON"
position before starting the engine.

REMOTE HORIZONTAL DEFLECTOR LEVER (E)

Move the lever forward to direct the flow of air
down. Move the lever back to direct the flow of
air up.

LOCKING KNOB (F)

Tighten the knob to lock the horizontal deflector
in the desired position. Loosen to allow the
deflector to be rotated with remote horizontal
deflector lever.

VERTICAL DEFLECTOR (G)

Rotate the deflector to direct air discharge
forward or to the side.

HORIZONTAL DEFLECTOR (H)

Directs air flow. Controlled by Remote Horizontal
Deflector Lever E. May be locked in place with
knob F.

Shown with Subaru EX40 engine

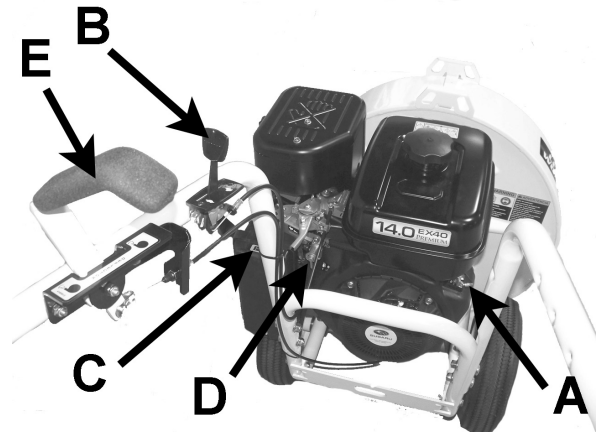

Kohler engine

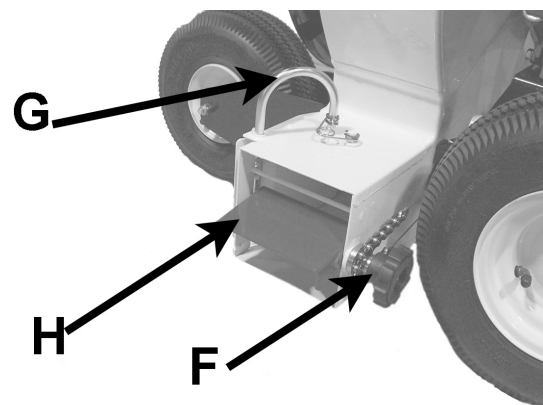

OPERATION

BEFORE STARTING THE ENGINE

1. Read the Operator Manual and Engine Manual. Become familiar with the controls, how each functions, and what it operates.
2. Check the engine oil level and add if necessary.
3. Fill the engine with oil and fuel as instructed in the Engine Manual.

OPERATING INSTRUCTIONS

Air flow can be directed to the side or front by the two-position vertical deflector. The front discharge position is used to remove debris from along walls, fences, etc. The side discharge position is used to form windrows or piles. The horizontal deflector directs air downward to “chisel” under wet, heavy leaves and litter. Air velocity is regulated by the throttle setting.

To reduce windrowing or to blow over an obstacle, point deflector upward.

To avoid blowing in an area, close deflector and reduce throttle setting.

Slight changes in deflector position will have a big effect on air flow. Experiment until you find the best position for your needs.

When clearing a yard or parking lot, a little time spent planning how to blow it off can greatly reduce the total clearing time.

To stop the engine, move the throttle control to the slow position and switch the engine off.

Stop the engine when moving from work site to work site. This will save fuel and prevent inadvertently blowing debris where you don't want to.

CAUTION

CLOSE THE FUEL VALVE WHEN TRANSPORTING THE MACHINE BY TRUCK OR TRAILER TO AVOID FLOODING.

MAINTENANCE INSTRUCTIONS

Stop engine and remove the spark plug wire before performing any maintenance.

Keep blower air intake clear of debris for best performance.

Clear air discharge area of any debris accumulation. Ensure machine has been shut off and fan is no longer moving before clearing.

Keep all hardware tight.

Check oil level daily. Top off as needed.

Change engine oil after the first 5 hours of operation. Then change as recommended by the engine manufacturer.

STORAGE

To prevent possible explosion or ignition of vaporized fuel, do not store equipment with fuel in tank or carburetor in an enclosure with open flame (for example, a furnace or water heater pilot).

Before the equipment is put into storage for any period exceeding 30 days, follow the instructions provided by the engine manufacturer.

To put the equipment into service after an extended period of storage.

1. Check for loose parts and tighten if necessary.
2. Fill the fuel tank and then check the engine oil level.
3. Start the engine and check for fuel leaks. Repair any leaks before operating the unit.

DEFLECTOR LEVER

If the deflector door moves from the set position during operation, tighten the deflector lever pivot bolt just enough to keep the deflector in place. **DO NOT over tighten, the handle tube could crush.**

HORIZONTAL DEFLECTOR

Adjust the jam nuts on the cable conduit so the deflector door is completely closed when the deflector lever is moved all the way forward. (Figure 1)

DEFLECTOR CHAIN

The sprocket needs to be installed on the deflector as shown. The chain consists of 2 master links, 6 roller links, and 5 pin links. The middle pin link should be over the center tooth of the sprocket. (Figure 2)

If large amounts of adjustment are required, the chain can be moved one pitch on the sprocket to gain 1/2" of adjustment.

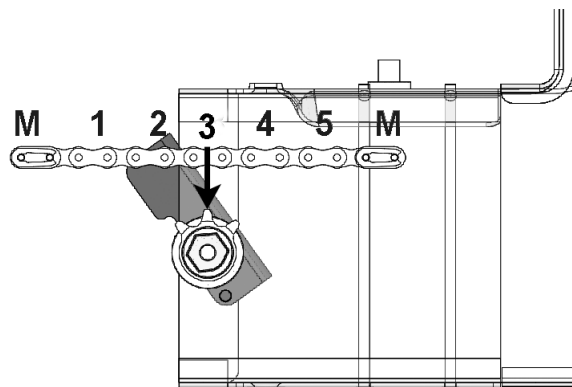
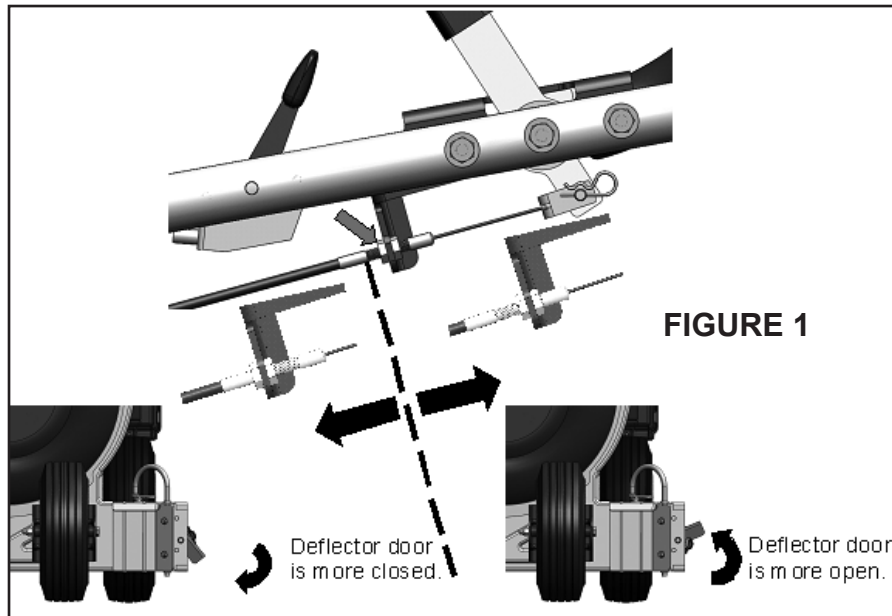

WARNING

**AVOID PERSONAL INJURY OR PROPERTY DAMAGE!
STOP ENGINE, WAIT FOR ALL PARTS TO STOP
MOVING, DISCONNECT THE SPARK PLUG BEFORE
PERFORMING ANY MAINTENANCE.**

FAN REMOVAL AND INSTALLATION

TOOLS REQUIRED

- 1/2" Wrench
- 9/16" (9390, 9570 models) torque wrench and wrench
- 5/8" (9270 model) wrench
- Impeller or external grip puller (if fan seized onto crankshaft).
- Loctite Silver LB 8150 anti-seize compound
- Red loctite 263
- Loctite 380 instant adhesive (if necessary)
-

INSTRUCTIONS:

1. Remove spark plug wire from spark plug and turn fuel shutoff to the **OFF** position. Always ensure the fan is not moving before performing any maintenance.
2. Remove fan cover nuts using a 1/2" wrench, and then remove the fan cover.
3. Remove the bolt that secures the fan to the engine crankshaft using a 1/2", 5/8", or 9/16" wrench.
4. If the fan does not slide off the crankshaft, the fan has a relief cut into the hub for use with a standard fan/impeller or external grip puller. The bolt that secures the fan to the engine crankshaft can be used as an extender if your fan puller does not have the necessary length to contact the end of the crankshaft.

5. Clean crankshaft internal threads with degreaser. Use compressed air and a clean rag to remove degreaser and any metal fragments on internal threads.

6. Apply Loctite Silver LB8150 anti-seize compound to the crankshaft.

(For steps 7-8, refer to the illustration on p. 15)

7. Install the spacer **4** on the crankshaft prior to installing the key. Replace damaged or worn fan **3** and key **5**. If the key is hard to position, reinstall it by applying a few drops of Loctite 380 instant adhesive on the key, and put the key in the keyway of the shaft. (Cure time is approximately 1 minute).
8. Slide plug **2** onto new bolt **1** in orientation shown under illustrated parts list.
9. Apply Red Loctite .263 to the entire length of the external threads on new bolt. Do not reuse the old bolt.
10. Torque bolt to:
50-90 lbs-ft for 9270 models
57-63 lbs-ft. for 9390 and 9570 models
11. Reinstall fan cover and tighten nuts using 1/2" wrench.
12. Tighten engine mount nuts using a 1/2" wrench.
13. Reattach spark plug wire to spark plug.
14. After installation, wait 24 hours before starting machine. Loctite must fully cure before the machine is used.

LITTLE WONDER BLOWER

FAN REMOVAL AND INSTALLATION

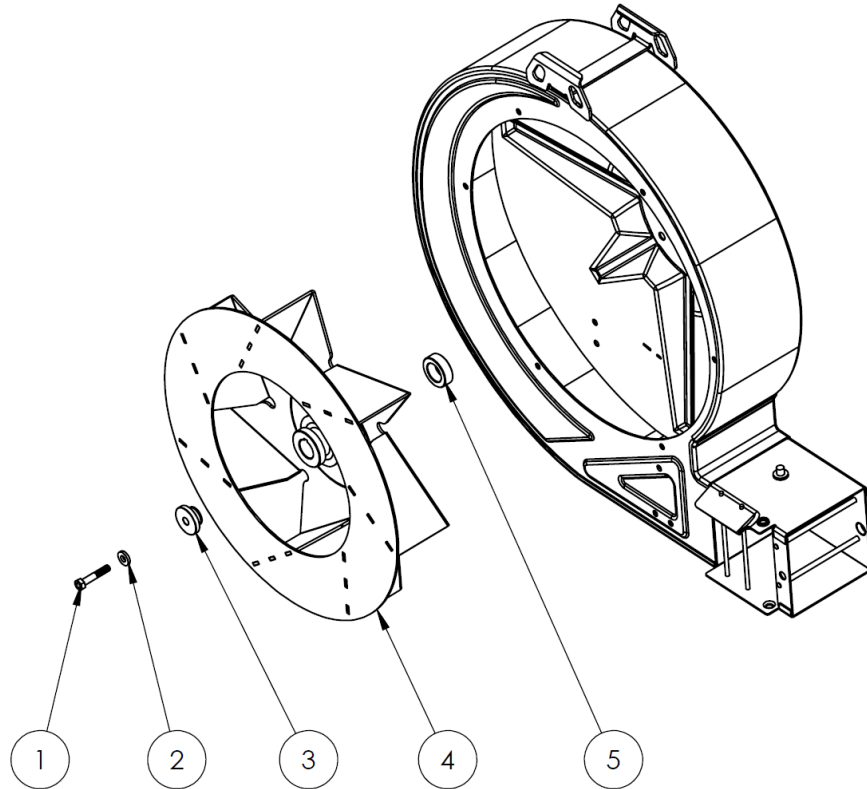

Item	Part No.	Description	Kit Number for Part	QTY
1	4177482-02 (91270,	BLT-HEX 7/16-20 X 1-3/4 GR8	4166887	1
	9270) 4177482-03 (9390,	BLT-HEX 3/8-24 X 1-3/4 GR8	4166888	1
	9400) 4177482-04 (9570)	BLT-HEX 3/8-24 X 2.5 GR 8	4176410	1
2	459-0001-03 (91270, 9270)	WSHR, 15/32 ID, 0.125 THK	4166887	1
	459-0001-02 (9390, 9400)	WSHR, 13/32 ID, 0.125 THK	4166888	1
	459-0001-02 (9570)	WSHR, 13/32 ID, 0.125 THK	4176410	1
3	4163427 (91270,	PLUG-FAN 7/16 X 1	4166887	1
	9270) 4163424 (9390,	PLUG-FAN 3/8 X 1.0	4166888	1
	9400) 4166437 (9570)	PLUG-FAN 18 VAN	4176410	1
4	4166730 (91270,	WLDMT-FAN, 8-9HP	4166887	1
	9270) 4166731 (9390,	WLDMT-FAN, 13HP/14HP	4166888	1
	9400) 4166992 (9570)	WLDMT-FAN, 9BL 3.50	4176410	1
5	4165169 (91270 & 9270 PUSH ONLY)	SPACER-FAN .53	4166887	1
	4165169 (9390 & 9400 PUSH ONLY)	SPACER-FAN .53	4166888	1
	4165170 (9570 PUSH ONLY)	SPACER-FAN 1.24	4176410	1
6 Not pictured	64164-13 (91270,	KEY-SQ 1/4 X 2	4166887	1
	9270) 64164-13 (9390,	KEY-SQ 1/4 X 2	4166888	1
	9400) 64164-40 (9570)	KEY-SQ 1/4 X 1-3/4	4176410	1

INTAKE GUARD ASSEMBLY

LITTLE WONDER BLOWER

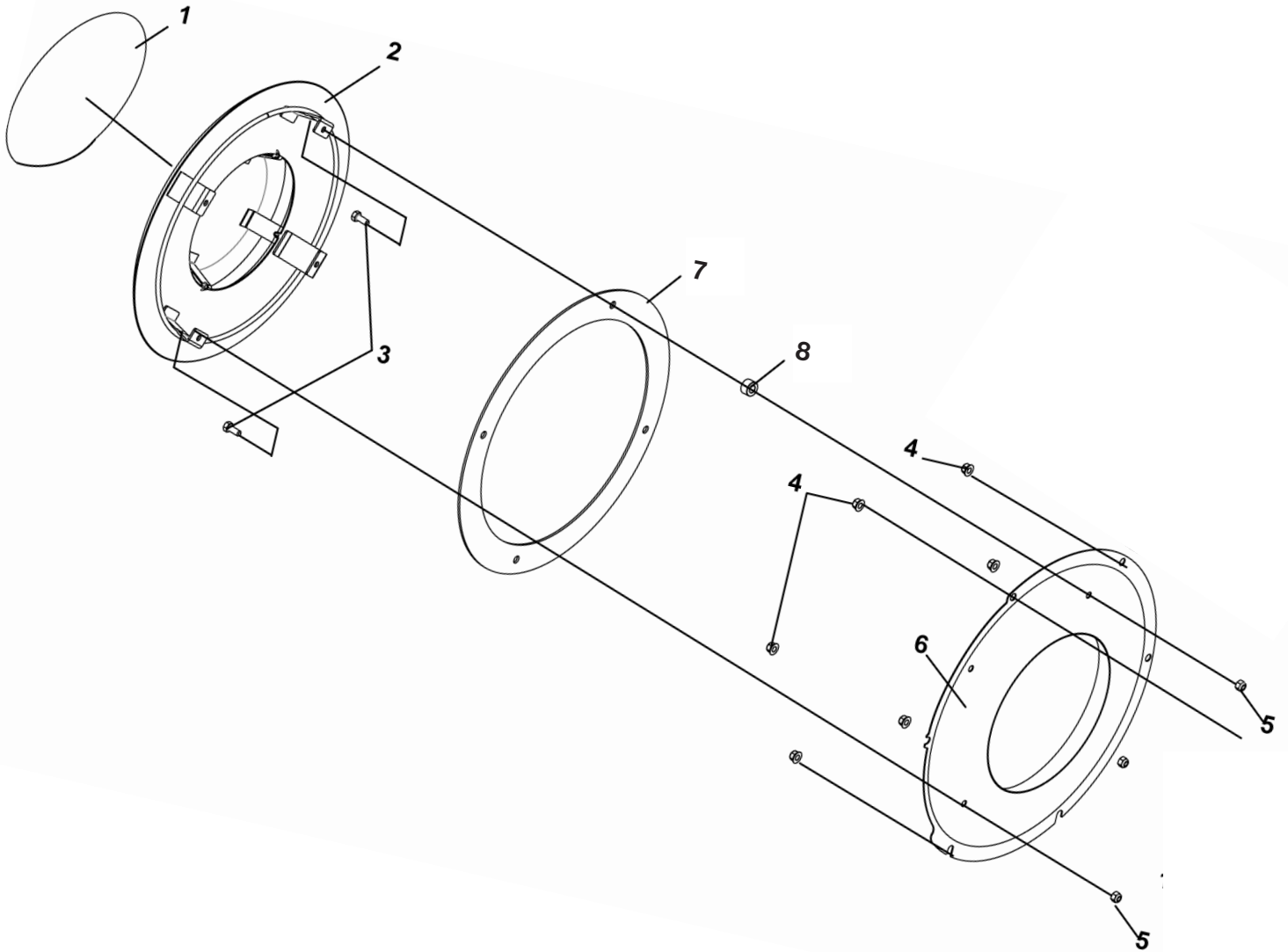

ITEM	PART NO.	DESCRIPTION	QTY
1	4166183	LABEL-INTAKE GUARD	1
2	4165218.7	ASSY-GUARD INTAKE	1
3	64123-54	BLT-HEX 5/16-18X.75	4
	64123-69	BLT-5/16-18 X 1 1/2 (USED ON 9570 MODEL ONLY)	
4	64268-02	NUT-FL NYLON LOCK 5/16-18	6
5	64229-02	NUT 5/16-18	4
6	4165926.10	INTAKE PANEL-CENTER	1
7	4166997	RING-INLET OFFSET (USED ON 9570 MODEL ONLY)	1
8	33030-09	BUSHING-.72 X .875 (USED ON 9570 MODEL ONLY)	4

LITTLE WONDER BLOWER

ENGINE ASSEMBLY

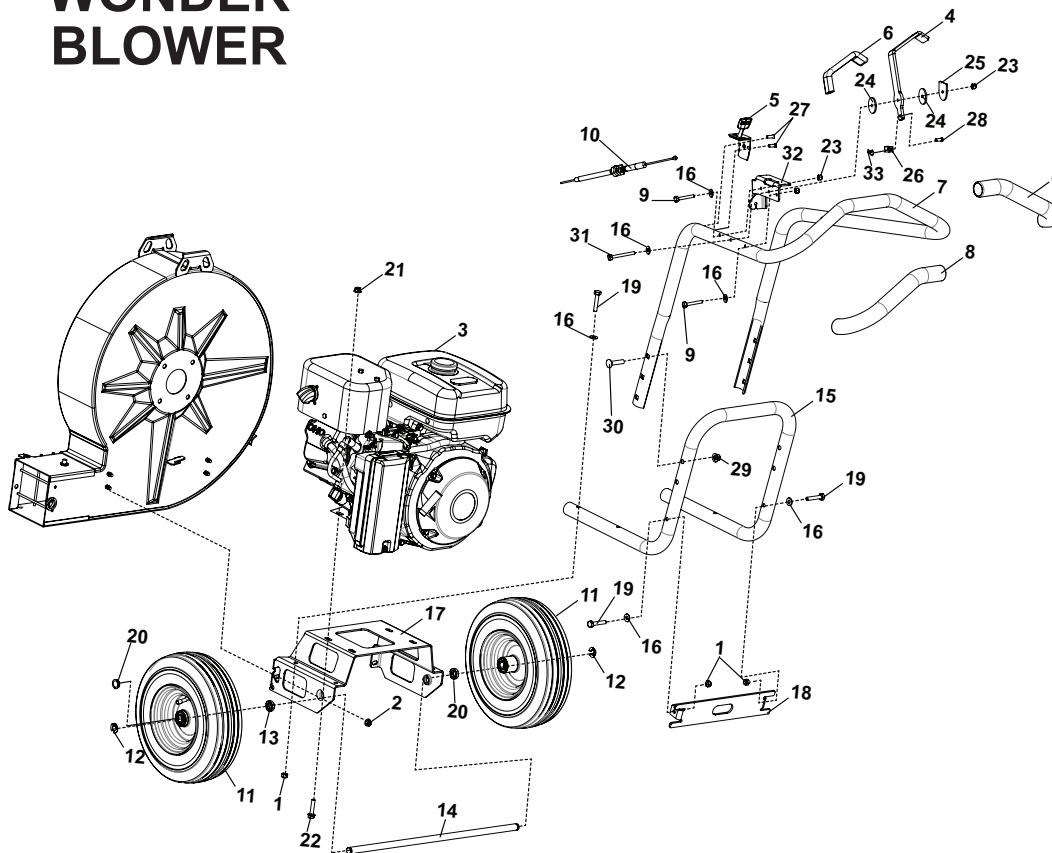

ITEM	PART NO.	DESCRIPTION	QTY	ITEM	PART NO.	DESCRIPTION	QTY
1	64229-02	LOCKNUT-NYL 5/16-18 (QTY 6 ON 9570 MODEL)	4	10	4166615	CABLE-PRE DEFLECTOR	1
2	64141-6	NUT 5/16-18	4	11	4164204	WHEEL-4.10/3.50 X 6	2
3	4166074	ENG-HONDA GX270 (USED ON 9270-02 MODEL)	1	12	64144-36	SNAP RING.625	2
	4165990	ENG-SUBARU EX27 (USED ON 9270-03 MODEL)	1	13	4164192-01	SPACER-PDR MTL 35X1.0X.25	2
	4166075	ENG-HONDA GX390 (USED ON 9390 MODEL)	1	14	4164178	AXLE	1
	4165993	ENG-SUBARU EX40 (USED ON 9400 MODEL)	1	15	4167557.10	HANDLE LOWER (USED ON 9270, 9390, 9400 MODELS)	1
	4166420	ENG-VANGUARD 18 (USED ON 9570 MODEL)	1		4164591.10	HANDLE-LOWER (USED ON 9570 MODEL)	1
	4174173	ENG-KOHLER CH395 (USED ON 9270-06 MODEL)	1	16	64163-55	WASHER-5/16 FLAT (QTY 6 ON 9570 MODEL)	4
	102-0002-00	ENG-KOHLER CH440 (USED ON 9390-06 MODEL)	1	17	4164588.7	DECK-ENGINE,BLR LG	1
4	4166778	S-LEVER W/ GRIP (INCLUDES ITEM 6)	1	18	4165895.10	BRACE-LOWER HANDLE (USED ON 9570 MODEL ONLY)	1
5	4166170-01	CABLE-THROTTLE (USED ON HONDA ENGINES)	1	19	64123-61	BLT-HEX 5/16-18X1-3/4 (QTY 6 ON 9570 MODEL)	4
	4166170-02	CABLE-THROTTLE (USED ON SUBARU ENGINES)	1	20	4164204-01	BEARING-WHL	4
	4166170-03	CABLE-THROTTLE (USED ON VANGUARD ENGINES)	1	21	64268-02	NUT-FL NYLON LOCK 5/16-18	4
	4166170-04	CABLE-THROTTLE (USED ON KOHLER ENGINES)	1	22	64262-009	BLT-FLGHD 5/16-18X1-1/2 (QTY 2 ON 9570 MODEL)	4
	4166170-01	CABLE-THROTTLE .25" (USED ON KOHLER CH440 ENGINES)	1		64262-019	BLT-FLG HD 5/16-18 X 1-3/4 (QTY 2 ON 9570 MODEL)	
6	4165987	GRIP-1/4X1X5 LEVER	1	23	64229-01	NUT-NYLON LOCK 1/4-20	1
7	4166779	S-HANDLE UPPER W/ GRIPS (INCLUDES ITEM 8 QTY 2)	1	24	4165854	WASHER- UHMW PE	2
8	4164632	GRIP-1-1/4 X 14	2	25	4165855.7	WASHER-ANTIROTATION	1
9	64123-283	BLT-HEX 1/4-20X1.75	2	26	4166457	CLEVIS-CABLE	1
				27	64139-26	BLT-WLF 10-32 X 5/8	2
				28	64188-65	PIN CLEVIS 1/4X.62	1
				29	64268-03	NUT-FL NYLON LOCK 3/8-16	4
				30	64018-5	BLT-CRG 3/8-16X1-3/4	4
				31	64123-98	BLT-HEX 1/4-20X2-1/2	1
				32	4166780	S-BRACKET,DEFLECTOR	1
				33	64168-2	COTTER-HAIRPIN .08X1.19	1

HOUSING ASSEMBLY

LITTLE WONDER BLOWER

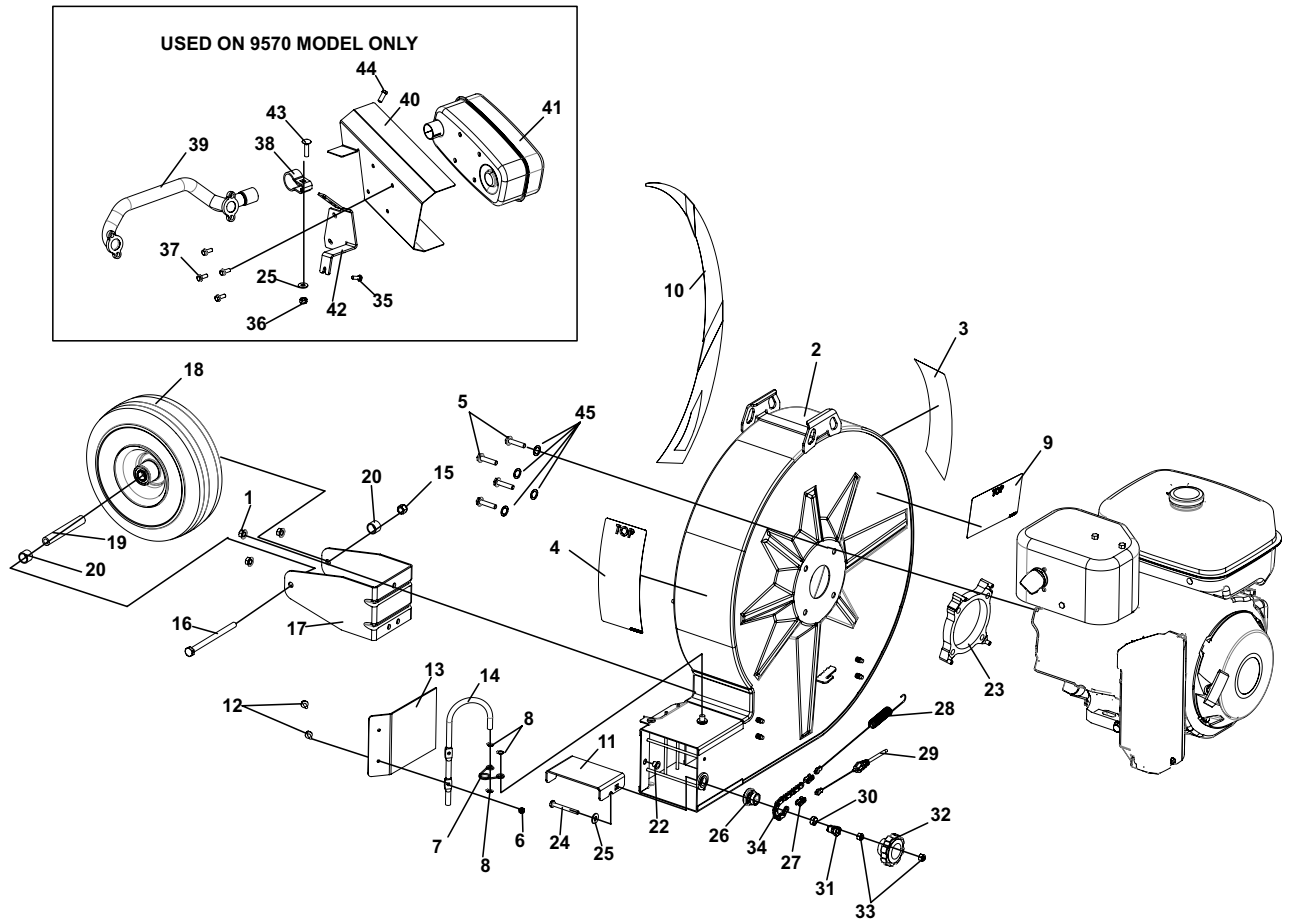

ITEM	PART NO.	DESCRIPTION	QTY	ITEM	PART NO.	DESCRIPTION	QTY
1	64141-6	NUT 5/16-18	3	28	4166614	CABLE-PUSH,POST DFLCTR	1
2	4166329	S-HOUSING LG BLOWER	1	29	4166615	CABLE-PUSH,PRE-DFLCTR	1
3	4166187	LABEL-BLOWER SIDE	1	30	4166324-02	BEARING-SLEEVE	1
4	4165975	LABEL-WARNING/DANGER	1	31	4166176	PIVOT-DEFLECTOR,INNER	1
5	910517	BLT-WLF 5/16-24 X 1-3/8	4	32	4166195	KNOB-1/4 FEMALE	1
6	64151-31	LOCKNUT-10-32	2	33	64229-01	NUT-NYLON LOCK 1/4-20	2
7	910130	SPRING-DEFLECTOR	1	34	4166618	CHAIN-DEFLECTOR	1
8	8-18	RING-RETAINING	3				
9	4165977	LABEL-READ MANUAL	1			ITEMS 35-44 USED ON 9570 MODEL ONLY	
10	4167331	LABEL-SCROLL	1	35	64205-021	BLT-M6 1X16	1
11	4166182.17	DEFLECTOR-SIDE	1	36	64025-02	NUT-HEX 5/16-18	1
12	64197-008	BLT-TDFM 10-32X1/2	2	37	64152-27	SCREW-SP 1/4-20 X 5/8	4
13	910123.10	DEFLECTOR-INT	1	38	35014N	CLAMP-MUFFLER	1
14	910132	HANDLE-DEFLECTOR	1	39	4166386	MANIFOLD-EXHAUST	1
15	64229-03	NUT-NYLON LOCK 3/8-16	1	40	4166390	SHEILD-HEAT	1
16	64123-252	BLT-HEX 3/8-16 X 5-1/2	1	41	108264	MUFFLER-B&S	1
17	4165178.7	BRKT-FRT WHL	1	42	4166349	BRKT-MUFFLER B&S	4
18	4164205	WHEEL-4.10/3.50X4	1	43	64018-14	BLT-CRG 5/16-18 X 1 1/4	1
19	900404	SLEEVE-WHEEL	1	44	64205-001	BLT-M8 1.25 X 20	1
20	900405	SPACER-FRT WHL BRKT	2				
21	4164204-01	BEARING-WHEEL	2	45	C500083	WASHER, 5/16 FLAT	4
22	38304-06	BEARING-FL PLASTIC .31 ID	1				
23	4166181	SPACER-ENG HOUSING	1				
24	64123-288	BLT-HEX 1/4-20 X 2-1/4	1				
25	64163-55	WSHR .328X.75X14 GA	1				
26	4166175	PIVOT-DEFLECTOR,OUTER	1				
27	4165192	LINK-MASTER #43	2				
						*NOT ILLUSTRATED	

Little Wonder Warranty Statement

Limited Warranty

Products Covered by This Warranty	LENGTH OF WARRANTY: FROM DATE OF ORIGINAL PURCHASE		
	PRIVATE RESIDENTIAL	COMMERCIAL	RENTAL
Hydro Brush Cutter	2 years	2 years	2 years
BedShaper®	2 years	2 years	2 years
Pro Edger	1 year	1 year	1 year
Pro Crack Cleaner	1 year	1 year	1 year
Electric Hedge Trimmer	2 years	2 years	2 years
Gas Hedge Trimmer	5 years	5 years	5 years
AgVac	2 years	2 years	2 years
TruckLoaders (All)	2 years	2 years	2 years
Pro Vac	2 years	2 years	2 years
C5 Blower	2 years	90 days	90 days
Optimax® Blower	5 years	5 years	5 years

Little Wonder products are warranted against defects in materials and workmanship for a period of time shown in the above table from the date of purchase from an authorized dealer by the original purchaser only, and under the following terms and conditions. Schiller Grounds Care's responsibility under this limited warranty is restricted to repairing or replacing, at its option, any covered part found to be defective in material or workmanship during the warranty period. All parts replaced under warranty will be considered as part of the original product and any warranty on the replaced parts will expire coincidentally with the original product warranty.

SCHILLER GROUNDS CARE, INC. MAKES NO EXPRESS OR IMPLIED WARRANTIES, REPRESENTATIONS, OR PROMISES EXCEPT THOSE CONTAINED HEREIN. THERE ARE NO OTHER WARRANTIES, INCLUDING WARRANTIES OF MERCHANTABILITY AND FITNESS FOR A PARTICULAR PURPOSE. ALL WARRANTIES OTHER THAN THE EXPRESS WARRANTY SET FORTH ABOVE ARE SPECIFICALLY DISCLAIMED. THE DURATION OF ANY IMPLIED WARRANTY, INCLUDING MERCHANTABILITY AND FITNESS FOR A PARTICULAR PURPOSE, IS LIMITED TO THE DURATION OF THIS WRITTEN LIMITED WARRANTY.

To Obtain Warranty Service - Warranty service must be performed by an authorized Little Wonder dealer. To locate a dealer, please visit: www.littlewonder.com and click on FIND A DEALER. For further assistance, write or email the Technical Services Department of Schiller Grounds Care

Schiller Grounds Care, Inc.
1028 Street Road
Southampton, PA 18966
techservicesupport@schillergc.com

ABOUT YOUR WARRANTY

The warranty period begins on the date of purchase by the original retail or commercial customer from an authorized Little Wonder dealer and is not transferable. Warranty service must be performed by an authorized Little Wonder dealer. If a warranty replacement becomes necessary, the authorized dealer must be prepared to provide the physical component for verification (freight prepaid) upon request from Schiller Grounds Care. Warranty service will be performed without charge to the purchaser for parts will be required to substantiate any warranty claim. Without proof of the initial purchase date from an authorized dealer, the manufacturing date of the product will be used to establish the warranty period.

Little Wonder Warranty Statement

EXCLUSIONS

This warranty only covers defects in materials or workmanship.

Engines and Other Manufacturers - Schiller Grounds Care makes no warranty with respect to engines or engine parts such as spark plugs, lubricants, starters, filters, and carburetors. The engine warranty is covered by the engine manufacturer. Consult the Operator's Manual for the engine provided with your product or ask an authorized dealer for the terms and conditions of these warranties. Schiller Grounds Care makes no warranty with respect to other parts not of its manufacture such as tires, batteries, gearboxes, or similar. These other parts may be covered by the warranties of their respective manufacturers.

Wear Items - This limited warranty does not cover damages or defects from normal wear and tear. This limited warranty does not include routine maintenance and normal maintenance parts, including but not limited to tires, batteries, transmissions, clutches, friction disks, blades, belts, chains, cables, hoses, bearings, non-metal liners, bags, or zippers.

Negligence and Improper Maintenance or Repair - This limited warranty does not cover any equipment that has been subject to lack of reasonable and proper maintenance, misuse, lack of proper storage, or accidents. This limited warranty does not cover any damage to the equipment that is caused by a freight carrier or is the result of failure to follow the operating instructions within the Owner's Manual. This limited warranty does not cover any defects due to repairs, modifications, or alternations made to the product by anyone other than Schiller Grounds Care or its authorized dealers. In addition, this limited warranty does not cover repairs made necessary due to a lack of proper protection during storage. This limited warranty does not cover damage caused by the use of parts, supplies, or accessories, including, without limitation, filters, spark plugs, carburetors, ignition, drive belts, brakes, gasoline, fuel, oil, or lubricants, which in the reasonable judgment of Schiller Grounds Care, are either incompatible with the product, adversely affect its operation, performance, durability or are other than as recommended in the Operator's Manual or other operational instructions provided by Schiller Grounds Care.

Improper Use - This limited warranty does not cover any Little Wonder Product, part, or accessory that (i) has been subject to misuse, abuse, neglect, negligence, or accident, or that has not been assembled, operated, or maintained in accordance with the operating or maintenance instructions specified in the Operator's Manual; or (ii) has been altered or modified so as to adversely affect its operation, performance or durability, or that has been altered or modified in ways not approved by Schiller Grounds Care. To the extent permitted by law, neither Schiller Grounds Care nor any company affiliated with it makes any warranties, representations, or promises as to the quality, performance, or freedom from defect of the Little Wonder Product, part, or accessory covered by this limited warranty. The authorized dealer makes no warranty of its own and such dealer has no authority to make any representation, warranty, or promise on behalf of Schiller Grounds Care or to modify the terms or limitations of this limited warranty in any way.

Other Exclusions - This limited warranty does not include reconditioned, refurbished, used, or demonstration equipment. This limited warranty excludes failures due to acts of nature beyond the manufacturer's control.

Extended Warranty - Schiller Grounds Care disclaims responsibility for any separately purchased extended warranty. ALL WARRANTIES OTHER THAN THE EXPRESS WARRANTY SET FORTH ABOVE ARE SPECIFICALLY DISCLAIMED. THE DURATION OF ANY IMPLIED WARRANTY, INCLUDING MERCHANTABILITY AND FITNESS FOR A PARTICULAR PURPOSE, IS LIMITED TO THE DURATION OF THIS WRITTEN LIMITED WARRANTY.

Disclaimer of Consequential Damage - Schiller Grounds Care disclaims any responsibility for incidental or consequential damages including, but not limited to, the expense for gasoline, the expense of delivering the product to an authorized service dealer, the expense of returning the product to the purchaser, mechanic's travel time, telephone charges, rental of a like product during the repair timeframe, travel, loss of revenue, loss of time, or inconvenience. SCHILLER GROUNDS CARE, INC. DISCLAIMS ALL LIABILITY FOR INDIRECT, INCIDENTAL, AND/OR CONSEQUENTIAL DAMAGES IN CONNECTION WITH THE USE OF THE LITTLE WONDER PRODUCTS COVERED BY THIS LIMITED WARRANTY. SOME STATES DO NOT ALLOW LIMITATIONS ON HOW LONG AN IMPLIED WARRANTY LASTS AND/OR DO NOT ALLOW THE EXCLUSION OR LIMITATION OF INCIDENTAL OR CONSEQUENTIAL DAMAGES, SO THE ABOVE LIMITATIONS AND EXCLUSIONS MAY NOT APPLY TO YOU. THIS WARRANTY GIVES YOU SPECIFIC LEGAL RIGHTS, AND YOU MAY ALSO HAVE OTHER RIGHTS WHICH VARY FROM STATE TO STATE.

